

★STAR VALVE BODIES

3 PORT - LOW PRESSURE

Forged Brass Body For Use With all Star Actuators

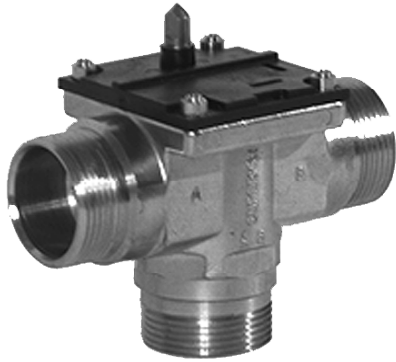

★Star™ 3 port
Low Pressure Body



BENEFITS & SPECIAL FEATURES

- Corrosion resistant 1-piece stainless steel stem
- Conical seats provide proportional flow when used with the Corvus, Pulsar and Regulus actuators.
- INSERT-A-SEAT™ allows field adjustable flow and pressure differential
- Balancing can be accomplished using 2 different seats
- Insulated Isotherm II™ bearing plate
- Heavy brass high quality forging
- Also available in a 2 port version
- Available in C X C, NPT, BSP, JIS, Compression, and Inverted flare
- Triple ZOLAST™ "o"-ring seal on stem
- Compatible with chilled or hot water
- 75 PSI (5.1 bar) static operating pressure
- UL certification: 30 PSI (2.0 bar) continuous duty
- UL tested to 150 PSI (10.2 bar) burst pressure

Operation

The ★Star bodies utilize a ball that swings between two orifices, or seats. The seats are conically shaped to provide proportional flow, ever decreasing as the ball approaches until 100% of the flow ceases. While the largest seat is machined directly out of the forged brass body, the smaller INSERT-A-SEATS™ are factory or field inserted to change the flow and pressure differential characteristics of the valve. The ball, stem and bearing plate are removable for cleaning or replacement. Since the plate forms a water-tight seal with the forging, the actuator may be removed without draining the system.

Application

The ★Star body is compatible with all ★Star actuators. Depending on the actuator chosen, the valve is suitable for systems requiring on-off, diverting (with or without priority), modulating or fully proportional control. Applications include, but are not limited to, zone control on hydronic systems, fan coils, control of domestic heating loops and storage tanks, humidity control and industrial process control.

Description

Every ★Star body is compatible with all ★Star actuators. ★Star valves are designed primarily for use on chilled or hot water and low-pressure steam. The valves are compatible with hundreds of other fluids in many environments.

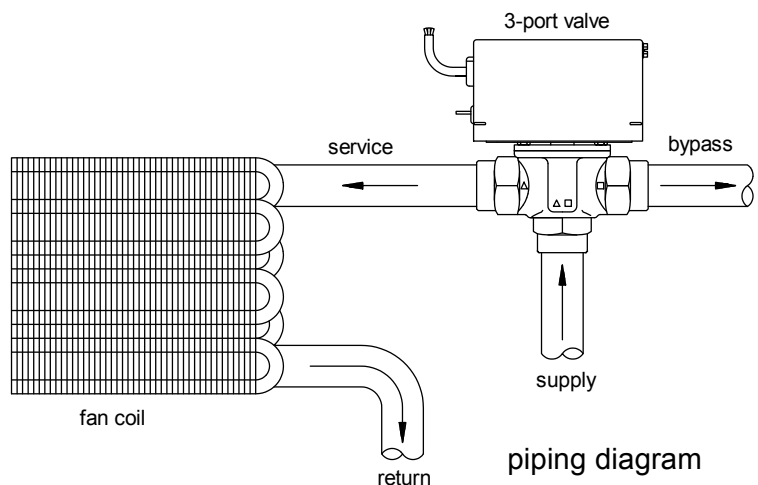

SPECIFICATIONS

PRESSURE

Static Pressure - water 100 PSIG / 40.8 bars

MAXIMUM TEMPERATURE LIMITS

Valve with actuator

Fluid

Standard 195°F / 91°C

High temp. option 250°F / 121°C

Ambient 110°F / 43°C

Body only (fluid)

Standard 375°F / 191°C

RATINGS

Orifice	Diameter		Standard or Option	Flow		Pressure Drop	
	in.	cm		Cv	Kv	PSI	BAR
Low	3/16	.476	Option	0.8	11.4	50	3.4
Med	6/16	.794	Option	2.9	41.4	25	1.7
High	9/16	1.11	Standard	4.8	68.5	10	.68

Kv based on Litres per minute flow, with pressure drop of 1kg/cm² at 20°C.

14.504 PSI = 1 BAR

For more detailed charts on flow and pressure consult the reference section.

MATERIALS

- STEM STAINLESS STEEL
- SEAT BRASS
- STEM O-RING ZOLAST™
- THREADED POST BRASS
- PRESSURE PLATE ISOTHERM II™
- PADDLE ZOLAST™
- BODY O-RING ZOLAST™
- BODY BRASS

DIMENSIONS

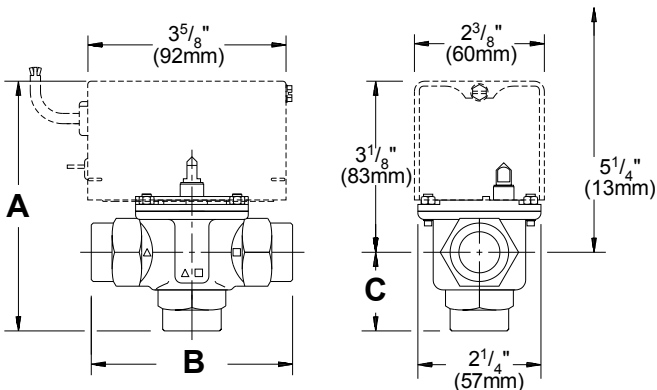

INSTALLATION

Valves are labelled with "W" and "□" symbols for port identification. 2-port valves are unidirectional when equipped with a N/O or N/C valve (Astral or Corvus), and bidirectional when equipped with the Lumina, Pulsar or Regulus actuators. Care should be taken when soldering valve bodies so that the paddle is away from the seat. Actuators need not be removed prior to soldering or installed prior to filling system.

Flair pursues a policy of constant improvement. For this reason, all specifications are subject to change without notice.

EXPLODED VIEW

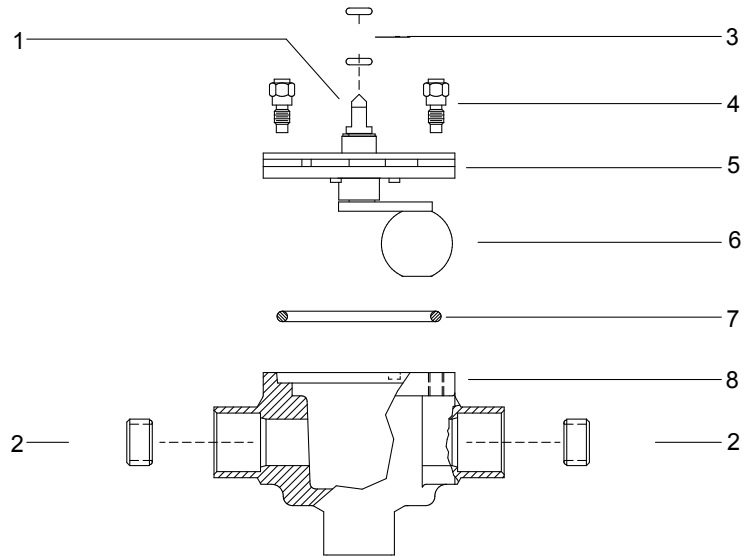

Body	Size	A	B	C
C X C Sweat	1/2"	4 5/16"	3 1/8"	1 1/4"
		110mm	79mm	32mm
	3/4"	4 9/16"	3 3/4"	1 1/2"
NPT BSP JIS	1/2"	4 7/8"	3 5/8"	1 3/4"
		124mm	92mm	45mm
	3/4"	4 3/4"	3 5/8"	1 3/4"
Comp- ression	1"	4 7/8"	4"	1 7/8"
		124mm	102mm	48mm
	1/2", 15mm	4 1/2"	3 1/4"	1 7/16"
3/4", 22mm		114mm	825mm	37mm
	1", 28mm	4 13/16"	3 11/16"	1 3/4"
		122mm	84mm	45mm
	1", 28mm	4 3/4"	3 7/8"	1 7/8"
		121mm	98mm	48mm

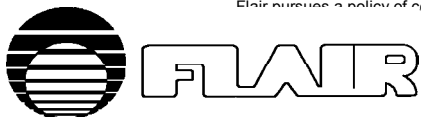

FLAIR INTERNATIONAL CORPORATION

600 Old Willets Path • Hauppauge, New York 11788 • Tel: (516) 234-3600 • Fax: (516) 234-3610